



**iSMA**  
**iSMA-B-MIX38**



Version: 2.0

SPECIFICATION	
Supply	DC: 24V ± 20%, 5W; AC: 24V ± 20%, 7.5VA
Universal inputs	8 - voltage, current and resistance measurement, dry contact
Digital inputs	12 - dry contact input, high-speed pulse counter up to 100Hz
Analog outputs	6 - 0-10V DC output, maximum load up to 20mA
Digital outputs	12 - relay output; Resistive load max. 3A@230VAC, 3A@30VDC Inductive load max. 75VA@230VA, 30W@30VDC
Interface	RS485, MODBUS or BACnet, up to 99 devices on the bus
Address	Set by switch in range from 0 to 99
Baudrate	Set by switch in range from 2400 to 115200 bps
Ingress Protection Rating	IP40 - for indoor installation
Temperature	Operating: -10°C to +50°C; Storage: -40°C to +85°C
Relative humidity	5 to 95% RH (without condensation)
Connectors	Separable, max 2.5mm <sup>2</sup>
Dimension	160mm x 110mm x 62mm
Mounting	DIN rail mounting (DIN EN 50022 norm)
Housing material	Plastic, self-extinguishing PC/ABS

**TOP PANEL**

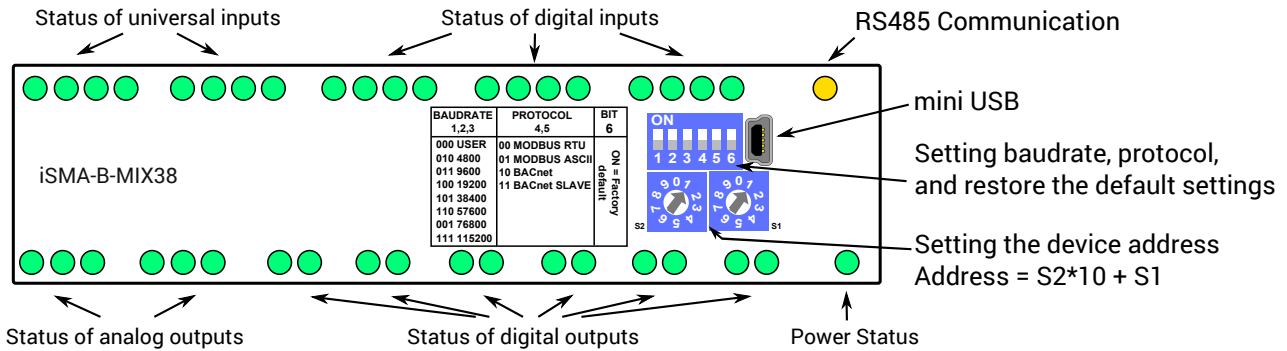

**UNIVERSAL INPUTS**

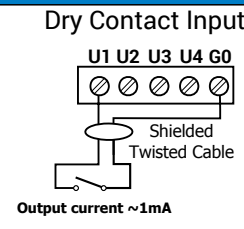
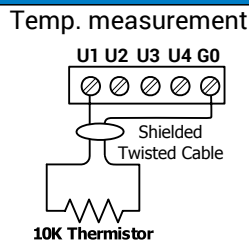
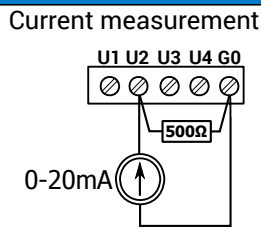
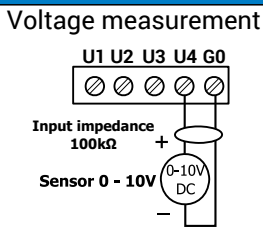

**DIGITAL INPUTS**

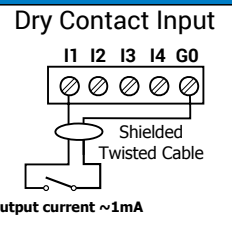

**DIGITAL OUTPUTS**

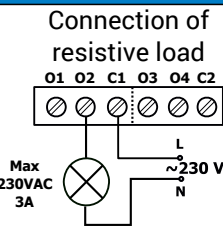
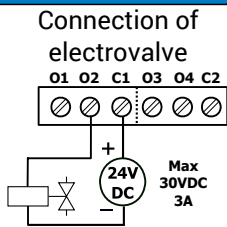

**COMMUNICATION**

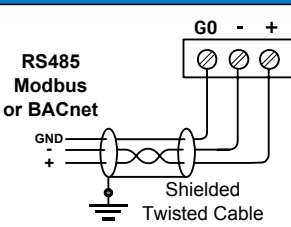

**POWER SUPPLY**

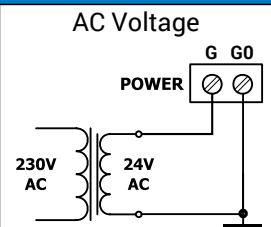
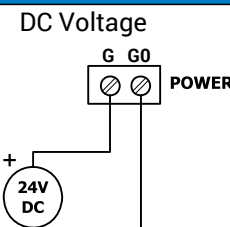

**ANALOG OUTPUTS**

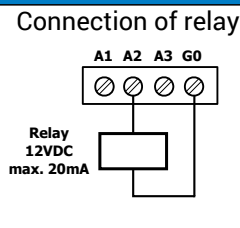
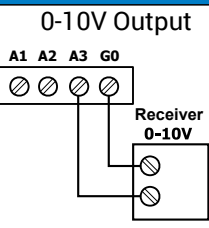

**CONNECTION ACTUATOR TO ANALOG OUTPUT**

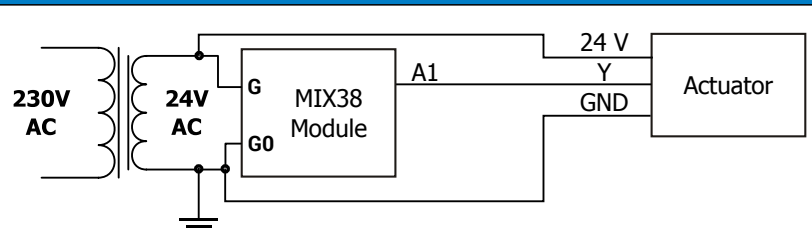

**WARNING**

- Note, an incorrect wiring of this product can damage it and lead to other hazards. Make sure the product has been correctly wired before turning the power ON.
- Before wiring, or removing / mounting the product, be sure to turn the power OFF. Failure to do so might cause electric shock.
- Do not touch electrically charged parts such as the power terminals. Doing so might cause electric shock.
- Do not disassemble the product. Doing so might cause electric shock or faulty operation.
- Use the product within the operating ranges recommended in the specification (temperature, humidity, voltage, shock, mounting direction, atmosphere etc.). Failure to do so might cause fire or faulty operation
- Firmly tighten the wires to the terminal. Insufficient tightening of the wires to the terminal might cause fire.

**TERMINALS OF THE DEVICE**

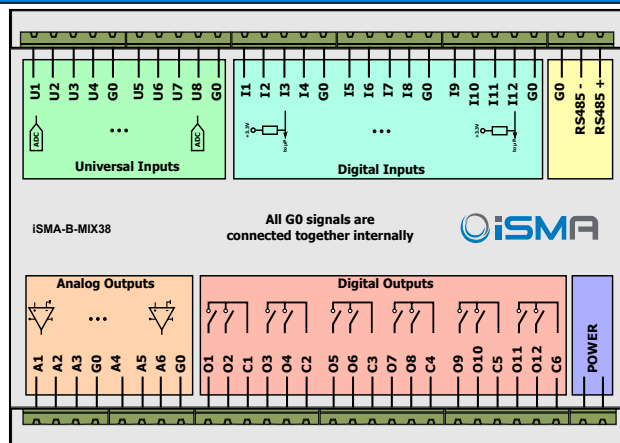

All G0 signals are connected together internally